



## EVENT FENCE

Event Fence portable barrier is a system of interlocking freestanding fence panels. Simply link Event Fence panels together to create continuous barricading for festivals, parades, sporting events or work sites. Optional forklift stillage makes storage and transporting of Event Fence panels simple and efficient.

### Features:

- Fully welded steel construction, galvanised finish.
- Panels nest together when not in use to reduce storage space.
- Optional stillages are available for use with forklifts.
- Vertical bars eliminate climbing points.
- Panels are able to pivot at joints.
- Low profile removable feet reduce tripping hazards.

<b>Material:</b>	Fully welded steel construction.
<b>Finish:</b>	Hot dip galvanised.
<b>Height:</b>	1100mm.
<b>Length:</b>	2200mm.
<b>Width:</b>	490mm.
<b>Weight:</b>	16kgs.

**Installation:** Freestanding panels, link together. No tools required.

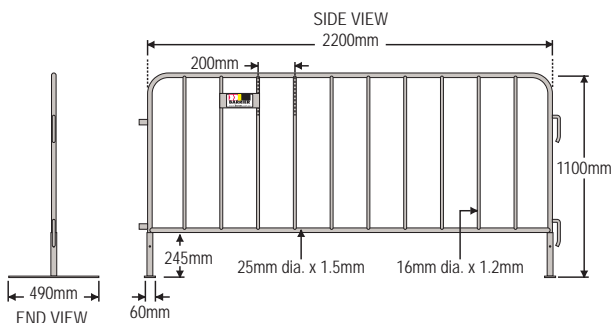

PART No.	DESCRIPTION
EF25/200	Event fence – standard duty
EFS	Event fence stackable forklift stillage – holds 30



## PORTABLE PLASTIC FENCE BARRIER

A low cost portable and stackable plastic fence for crowd control or closing off worksites. Manufactured from durable polyethylene in a high visibility Orange colour. Black feet made from recycled rubber rotate to the flat position for stacking.

### Features:

- Hi-Vis Orange super tough polyethylene barrier.
- Black recycled rubber feet rotate for flat packing.
- Lightweight for portability.
- High visibility colour with reflective panels.

<b>Material:</b>	Moulded polyethylene.
<b>Finish:</b>	Solid colour Hi-Vis Orange.
<b>Height:</b>	1000mm.
<b>Length:</b>	2000mm.
<b>Weight:</b>	13kgs.



PART No.	DESCRIPTION
PFB200	Portable plastic fence barrier