

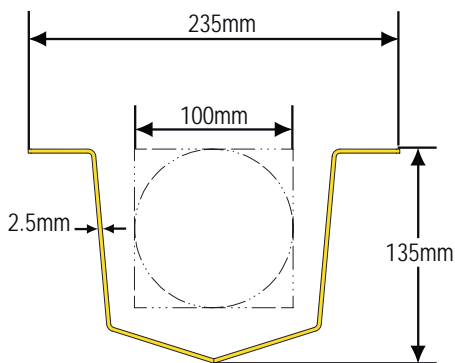

BULL-DOG DOWNPIPE PROTECTOR
For downpipes up to 100mm diameter

Features:

- Protects pipes and cables from vehicle damage.
- Clearly visible to reversing vehicles.
- Suitable for services up to 100mm diameter.
- Robust 2.5mm thick mild steel construction.
- 6 off 10mm pre-drilled mounting holes.
- Easily retrofitted to existing services.
- Suitable for indoors or outdoor use.
- Hot dip galvanised with Yellow powder coat.
- 900mm high for maximum protection.



PART No.	DESCRIPTION
BDP100	Bull-Dog 100mm downpipe protector (7.8kgs)



BULL-DOG DOWNPIPE PROTECTOR
For downpipes up to 200mm diameter

Features:

- Protects pipes and cables from vehicle damage.
- Clearly visible to reversing vehicles.
- Suitable for services up to 200mm diameter.
- Robust 3mm thick mild steel construction.
- 6 off 10mm pre-drilled mounting holes.
- Easily retrofitted to existing services.
- Suitable for indoors or outdoor use.
- Hot dip galvanised with Yellow powder coat.
- 900mm high for maximum protection.

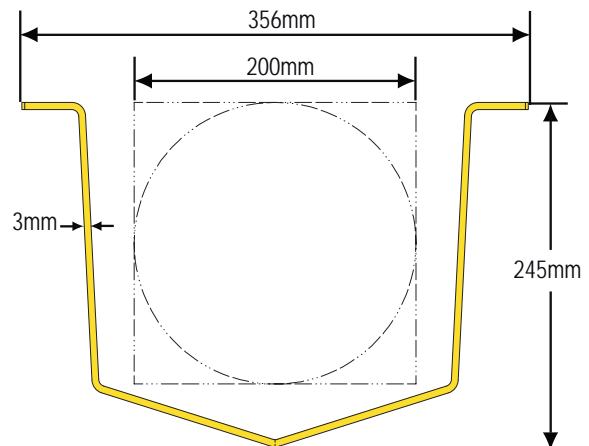

PART No.	DESCRIPTION
BDP200	Bull-Dog 200mm downpipe protector (16kgs)